

# S3210P

## PUSH-AROUND MINI SCISSOR LIFT



- Outdoor-rated
- Simple to use; easy to maintain
- No stabilizers required
- Durable design for tough site conditions
- Proven benefits over other low level access products

**snorkel**<sup>™</sup>  
[www.snorkellifts.com](http://www.snorkellifts.com)

# PUSH-AROUND MINI SCISSOR LIFT

# S3210P

DIMENSIONS	S3210P*
Max. working height	5.0m
Max. platform height (A)	3.0m
Platform size (outside)	1.1m x 0.52m
Overall width (B)	0.81m
Overall length (C)	1.2m
Stowed height (D)	1.8m

PERFORMANCE	
Platform capacity (SWL)	240kg
Max. wind speed	12.5m/s
Raise/lower time	19/26 sec

POWER	
Power source	12V DC battery
Battery charger	Built in multi-voltage (90V - 240V)

WEIGHT	
Weight	470kg

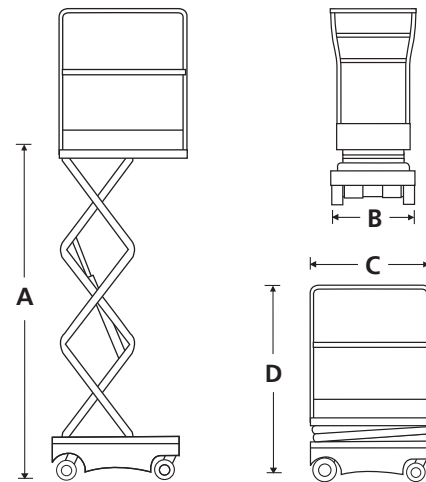

## STANDARD FEATURES

- Outdoor-rated
- Auto brake system
- Tilt sensor
- Saloon-door style entry gates
- Integrated battery charger 90V - 240V
- Battery charge indicator
- Forklift pockets
- Emergency lowering system
- Non-marking casters
- Slide-out service trays
- 2 year parts & labour, 5 year structural warranty
- CE approved

## OPTIONS

- Special paint colours
- Environmental hydraulic oil
- Snorkel OnSite™ telematics

## PLATFORM HEIGHT

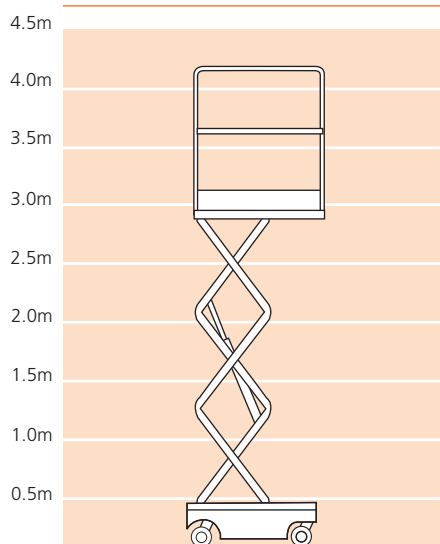

S3210P

**snorkel** [www.snorkellifts.com](http://www.snorkellifts.com)

Vigo Centre, Birtley Road,  
Washington, Tyne & Wear,  
NE38 9DA, U.K.

t: +44 (0) 845 1550 057  
e: sales.emea@snorkellifts.com